

ECLIPSE SEAT

FFSC002015X - Eclipse - Seat - W/Armrests - 1800mm - Plinth Mount

SPECIFICATIONS SLATS

CODE	MATERIAL SLATS	FINISH SLATS	MATERIAL FIXINGS
FFSC002020	HARDWOOD TIMBER	STANDARD STAIN	STAINLESS STEEL
FFSC002020A	ALUMINIUM	CLEAR ANODISED	STAINLESS STEEL
FFSC002020APC	ALUMINIUM	POWDER COATED	STAINLESS STEEL
FFSC002020ATE	ALUMINIUM	TIMBER EFFECT	STAINLESS STEEL

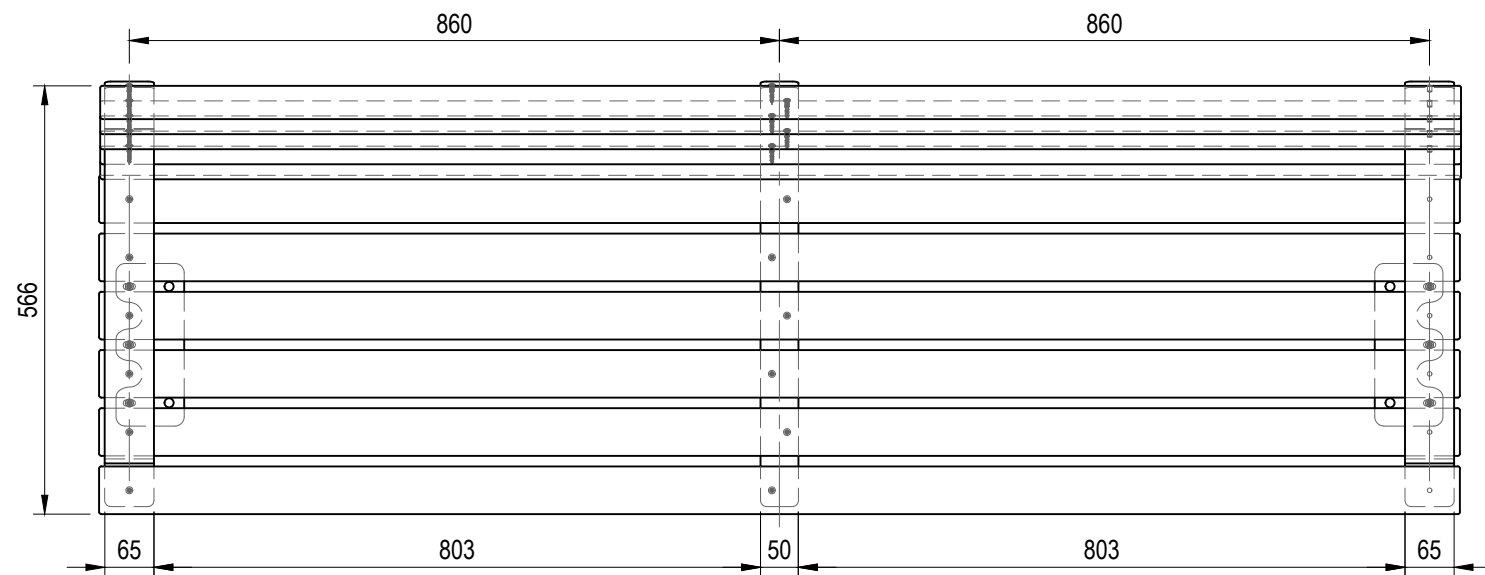

TOP VIEW

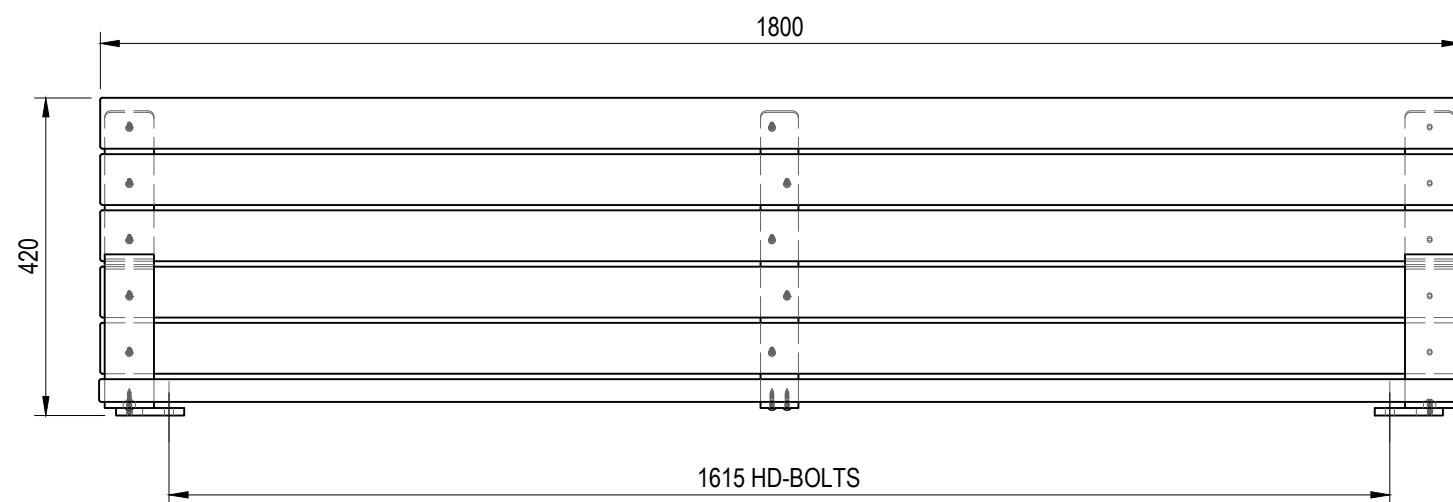

FRONT VIEW

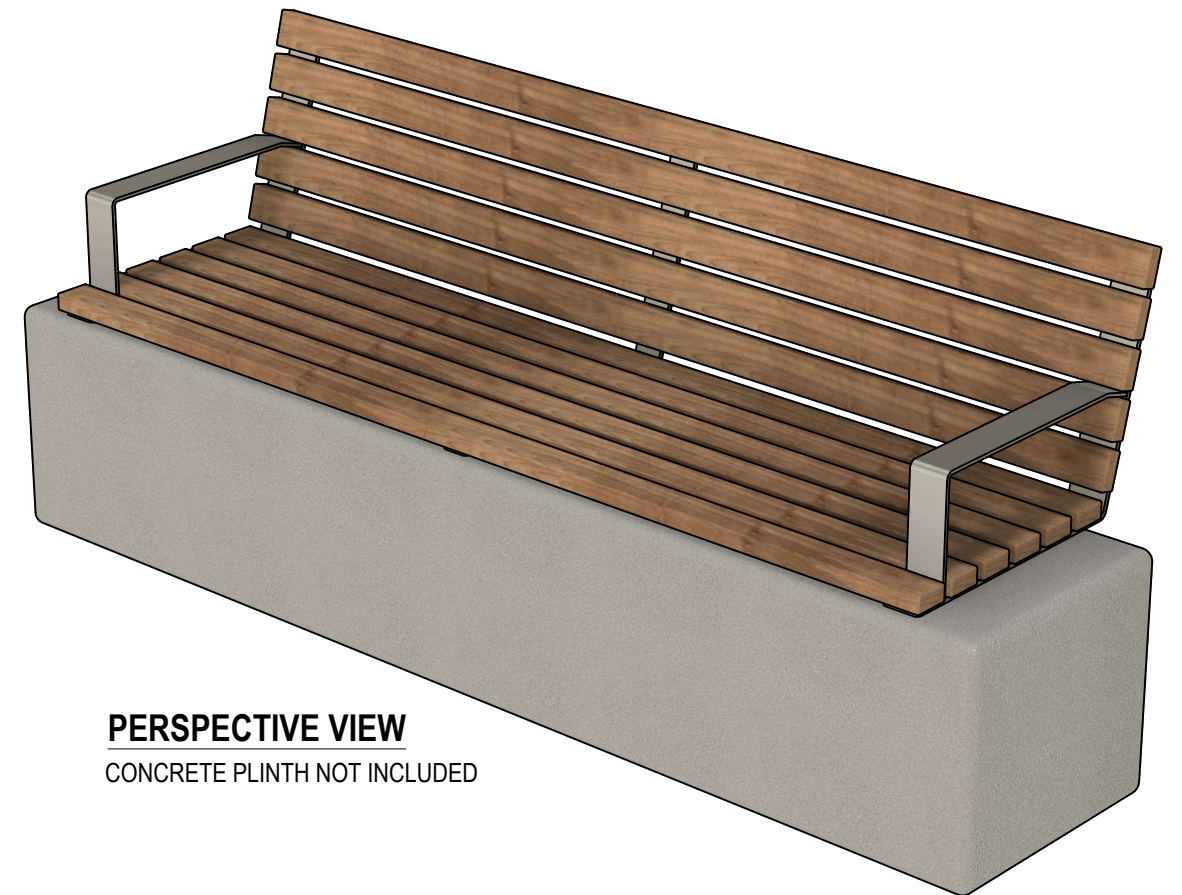

PERSPECTIVE VIEW

CONCRETE PLINTH NOT INCLUDED

SPECIFICATIONS:

MAIN CONSTRUCTION

MATERIALS:

- Legs - Stainless Steel 304
- Brackets - Stainless Steel 304

FINISH:

- STANDARD:
- Powder coated

GROUND FIXING OPTIONS

- Bolt Down (BD): M10 x 75mm Screwbolt Anchor GAL
- In Ground (IG): HD Bolt Kit GAL

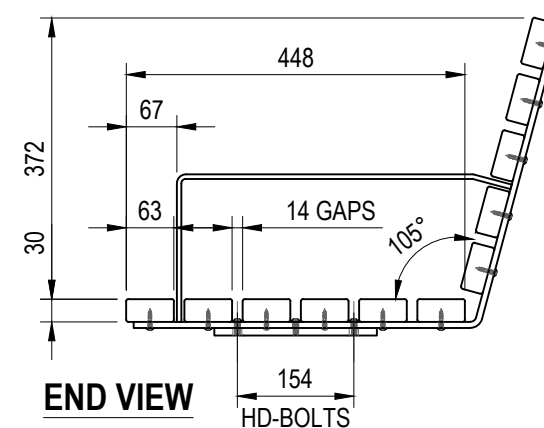

END VIEW

Revision History

Rev	Description	Date	Approved



© FURPHY FOUNDRY PTY LTD.

THIS DOCUMENT IS AND SHALL REMAIN THE PROPERTY OF FURPHY FOUNDRY. UNAUTHORISED USE OF THIS DOCUMENT IN ANY FORM IS PROHIBITED.

UNLESS OTHERWISE SPECIFIED, DIMENSIONS ARE IN mm
DO NOT SCALE
BREAK ALL SHARP EDGES AND REMOVE BURRS

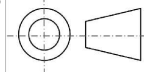

TOLERANCES
X: ±0.25
Y: ±0.1
XX: ±0.05
ANGLES: ±0.1°



Furphy Foundry Pty Ltd
A.B.N. 24 007 195 913
21 Drummond Rd,
Shepparton VIC 3630
PH: (03) 5831 2777
FAX: (03) 5831 2681
www.furphyfoundry.com.au
sales@furphyfoundry.com.au

CLIENT NAME	PROJECT No.	PAGE
Furphy Foundry	ECLI-1011	A3
PROJECT	DATE:	DRAWN
Eclipse Furniture Range	26/11/2024	Joel Rose
FFSC002015X - Seat - W/Armrests - 1800mm - Plinth Mount	DRAWING No.	SCALE
	ECLI-00010-SPE	1:20
DRAWING TITLE	PART No.	SHEET No.
Eclipse - Seat - W/Armrests - 1800mm - Plinth Mount - Specification	FFSC002015X	1/1
REV.	----	----