

AXIS BENCH - STRAIGHT - MODULAR

FFSC001083 - Modular Straight Bench - Plinth Mount

NOTE: MODULAR CONFIGURATION SHOWN IS FOR EXAMPLE PURPOSES ONLY. SITE-SPECIFIC DRAWINGS WILL BE REQUIRED BASED ON THE FINAL ORDER AND FURNITURE CONFIGURATION

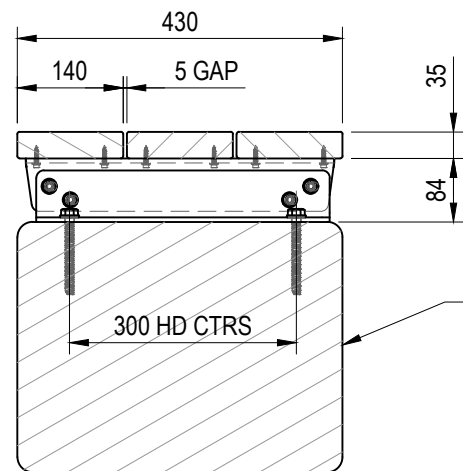

SECTION A-A (1:10)

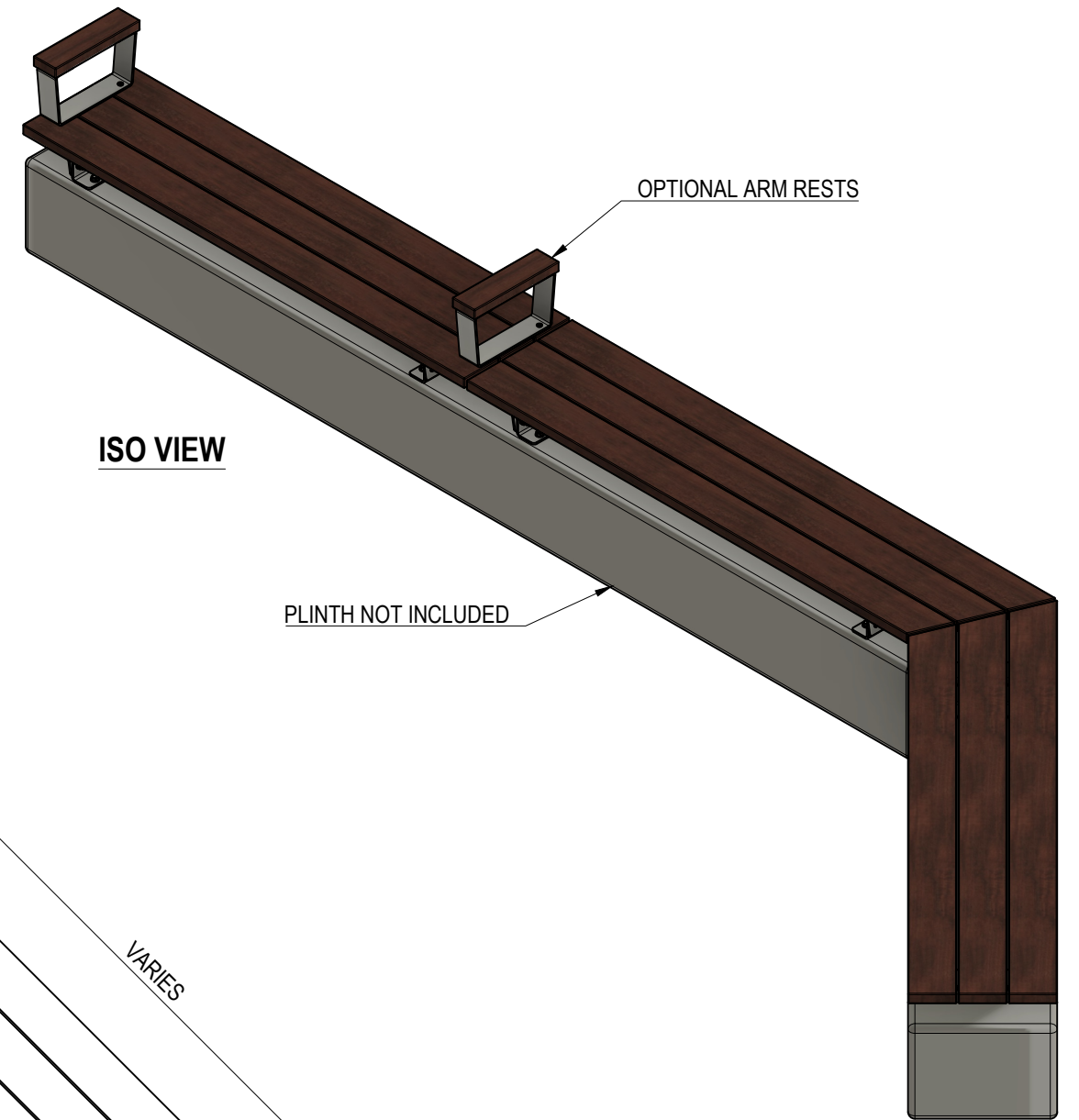

ISO VIEW

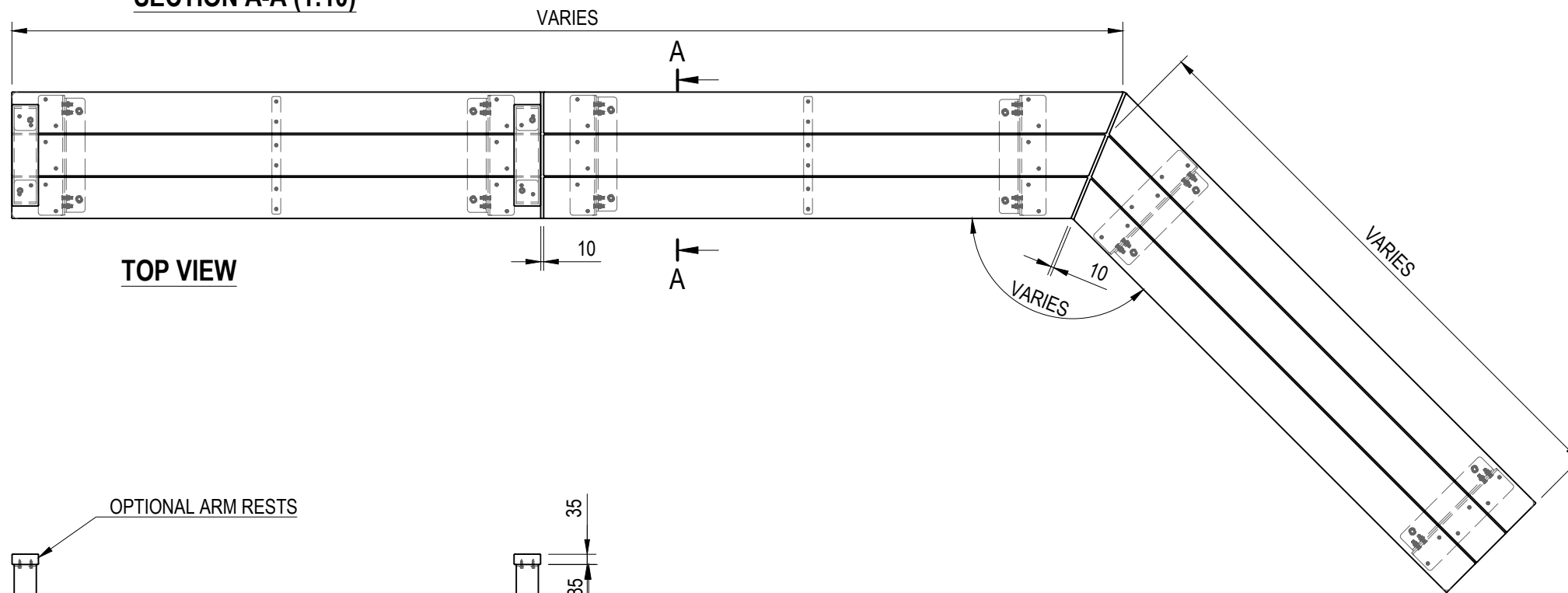

TOP VIEW

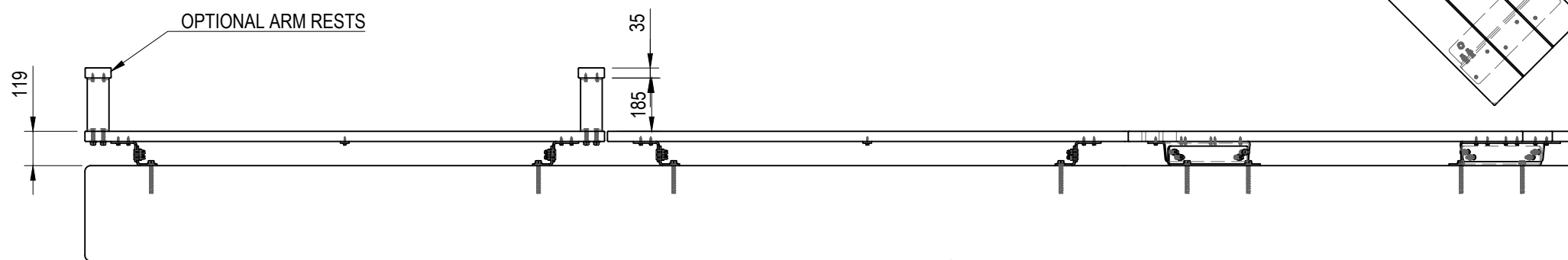

FRONT VIEW

SPECIFICATIONS:

- FRAME:** STAINLESS STEEL 304 GRADE & POWDERCOAT FINISH
- FIXINGS:** STAINLESS STEEL UNLESS NOTED OTHERWISE
- SLATS:** KILN DRIED HARDWOOD DRESSED ALL SIDES WITH PENCIL ROUNDED EDGES

Revision History

Rev	Description	Date	Approved

FURPHY FOUNDRY PTY LTD.

THIS DOCUMENT IS AND SHALL REMAIN THE PROPERTY OF FURPHY FOUNDRY. UNAUTHORISED USE OF THIS DOCUMENT IN ANY FORM IS PROHIBITED.

UNLESS OTHERWISE SPECIFIED, DIMENSIONS ARE IN mm
DO NOT SCALE
BREAK ALL SHARP EDGES AND REMOVE BURRS

TOLERANCES
X: ±0.25
Y: ±0.1
XX: ±0.05
ANGLES: ±0.1°

FURPHY
FOUNDRY EST. 1864

Furphy Foundry Pty Ltd
A.B.N. 24 007 195 913
21 Drummond Rd,
Shepparton VIC 3630

PH: (03) 5831 2777
FAX: (03) 5831 2681
www.furphyfoundry.com.au
sales@furphyfoundry.com.au

CLIENT NAME FURPHY FOUNDRY	PROJECT No. FFSC001083	PAGE A3
PROJECT Axis Furniture Range FFSC001083 - Modular Straight Bench - Plinth Mount	DATE: 18/09/2024	DRAWN Joel Rose
DRAWING TITLE Modular Straight Bench - Plinth Mount	PART No. FFSC001083	SCALE 1:20
	SHEET No. 1/1	REV.